



Figure 10: Elstein FSF series

Elstein FSF panel radiators, are ceramic infrared radiators with a low overall height. They are produced using a full-pour casting ceramic process and are designed for operating temperatures up to 750 °C and surface ratings up to 64 kW/m².

Compared to other Elstein panel radiators, the overall height of the FSF radiators, measured from the radiation surface up to the mounting plate, has been reduced by approximately 45%.

FSF series radiators can be used universally. The low overall height of the radiators enables space-saving installation, for example, which may be required to retrofit machines.

FSF radiators are available in four designs and cover the power range from 60 W to 1000 W.

Elstein FSF panel radiators have the customary market dimensions and can therefore be replaced with radiators with corresponding properties if the requirements change.

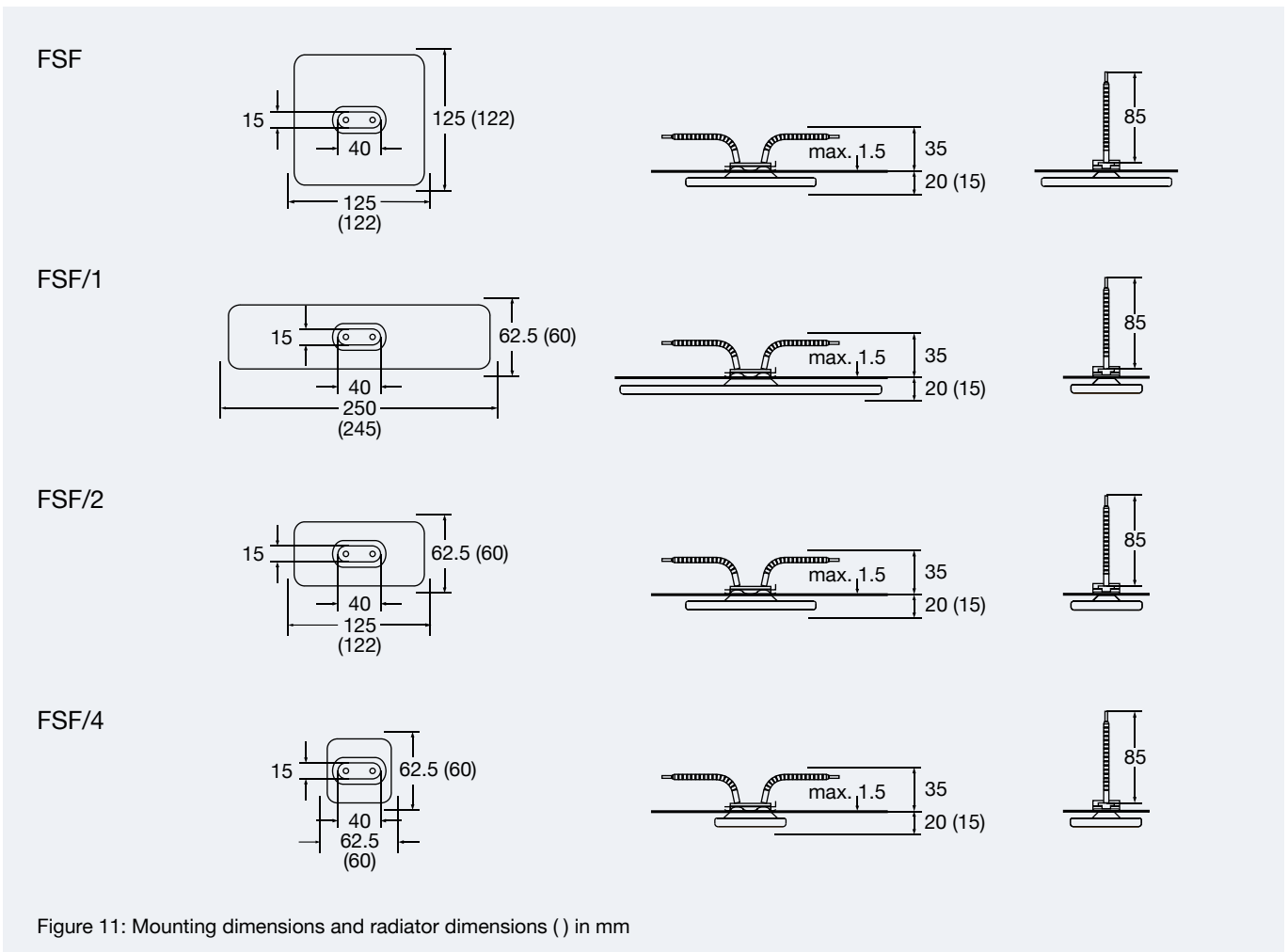

Figure 11: Mounting dimensions and radiator dimensions () in mm

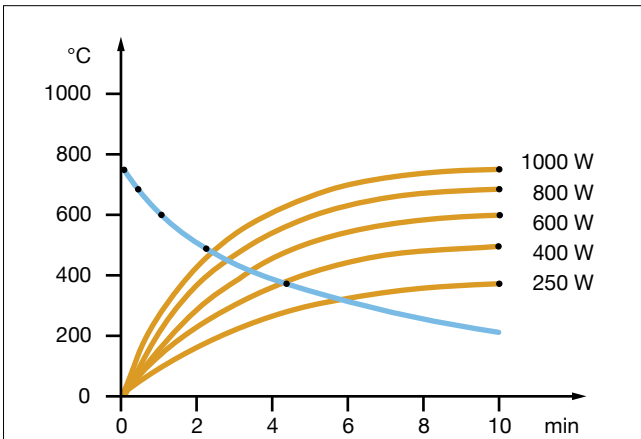

Fig. 12: Radiator temperatures
Heating-up: red curves
Cooling-down: blue curve

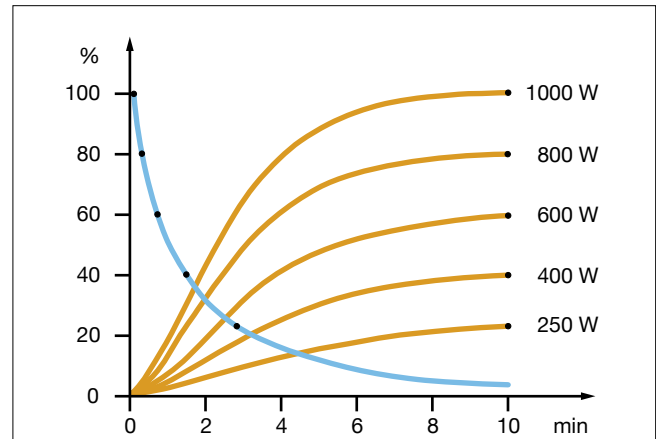

Fig. 13: Radiant powers
Heating-up: red curves
Cooling-down: blue curve

Type, weight, wattage	FSF/1, FSF	220 g	250	400	600	800	1000	W
	FSF/2	125 g	125	200	300	400	500	W
	FSF/4	75 g	60	100	150	200	250	W
Surface rating			16.0	25.6	38.4	51.2	64.0	kW/m ²
Typical operating temperature			400	500	590	670	720	°C
Maximum permissible temperature			750	750	750	750	750	°C
Wavelength range			2 - 10					μm

<p>Standard design</p> <p>Operating voltage 230 V Ceramic full-pour casting Leads 85 mm Elstein standard socket Mounting set</p>	<p>Thermocouple radiator</p> <p>Integrated thermocouple Type K (NiCr-Ni) Designation T-FSF, T-FSF/1, T-FSF/2, T-FSF/4 TC leads 100 mm</p>	<p>Variants</p> <p>Special wattages Special voltages Extended leads Live leads with ring terminals</p>
---	--	---

The power can be controlled using thermocouple radiators together with TRD temperature controllers, TSE thyristor switching units and other accessories.

IR radiation areas can be assembled using MBO mounting sheets.

The national safety regulations must be complied with for the respective application, for example, the IEC or EN standard 60519-1, Safety in electrical heating installations.

Further information and safety information are given in the mounting instruction enclosed with each radiator.