



Figure 34: Elstein FSL series

Elstein FSL long panel radiators are ceramic infrared radiators with a low overall height, designed for operating temperatures up to 700 °C and surface ratings up to 45 kW/m<sup>2</sup>.

They have two sockets with integrated twisted litz fixing wires, so that FSL radiators are easy to install and are space-saving. No special pre-punched holders or reflector plates are required for the assembly.

FSL series radiators are particularly suitable for lamellar heating tasks due to their long narrow design.

An example for lamellar heating tasks can be found in the lamp industry where FSL radiators are used for curing the coating of fluorescent tubes.

Elstein FSL long panel radiators are available in two designs with 300 W and 600 W.

## FSL

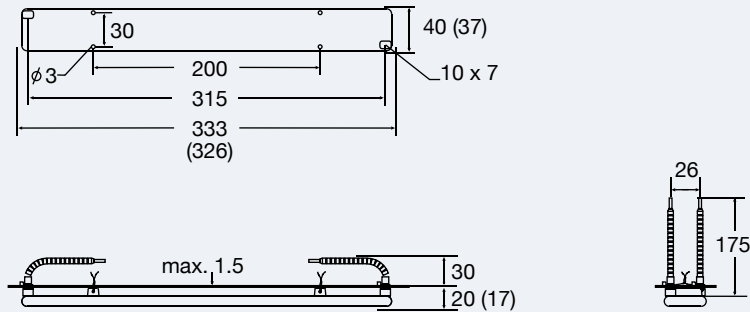

## FSL/2

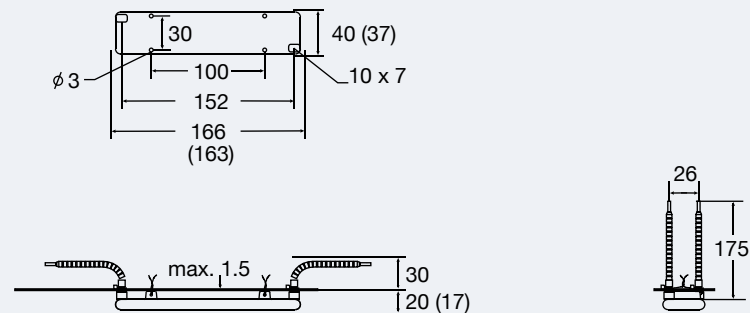
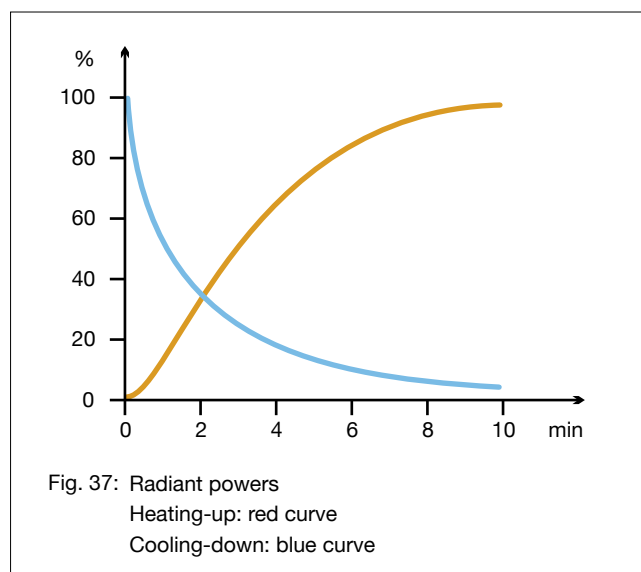
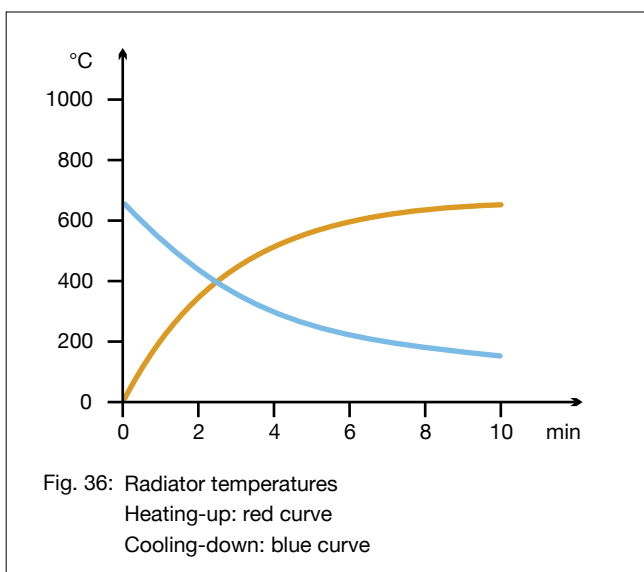

Figure 35: Mounting dimensions and radiator dimensions ( ) in mm



Type, weight, wattage	FSL	220 g	600	W
	FSL/2	130 g	300	W
Surface rating			45.0	kW/m <sup>2</sup>
Typical operating temperature			550	°C
Maximum permissible temperature			700	°C
Wavelength range			2 - 10	μm

Standard design	Thermocouple radiators	Variants
Operating voltage 230 V Ceramic full-pour casting Leads 175 mm Two litz mountings	Integrated thermocouple Type K (NiCr-Ni) Designation T-FSL, T-FSL/2 TC leads 110 mm	Special wattages Special voltages Extended leads Live leads with ring terminals

The power can be controlled using thermocouple radiators together with TRD temperature controllers, TSE thyristor switching units and other accessories.

The national safety regulations must be complied with for the respective application, for example, the IEC or EN standard 60519-1, Safety in electrical heating installations.

Further information and safety information are given in the mounting instruction enclosed with each radiator.