

Low profile end seal - cold applied





The E-150 is a cold applied low profile end seal. This universal end seal is designed to fit with all Raychem industrial heating cables; BTV, QTVR, XTV and KTV meaning simplified product selection and reduced inventory to stock. It can be used in applications with temperatures ranging from -50°C to 215°C . It is approved for use in hazardous areas.

The unique design of the E-150 suits the demanding requirements of the industrial environment. The low profile housing can be installed on pipes and other surfaces. A spring loaded grommet makes a first seal to maintain a water tight connection while the non-curing sealant (silicone free) used in Raychem's core sealing boot adds a second seal, providing additional protection. The rugged construction of the end seal makes it resistant to impact and

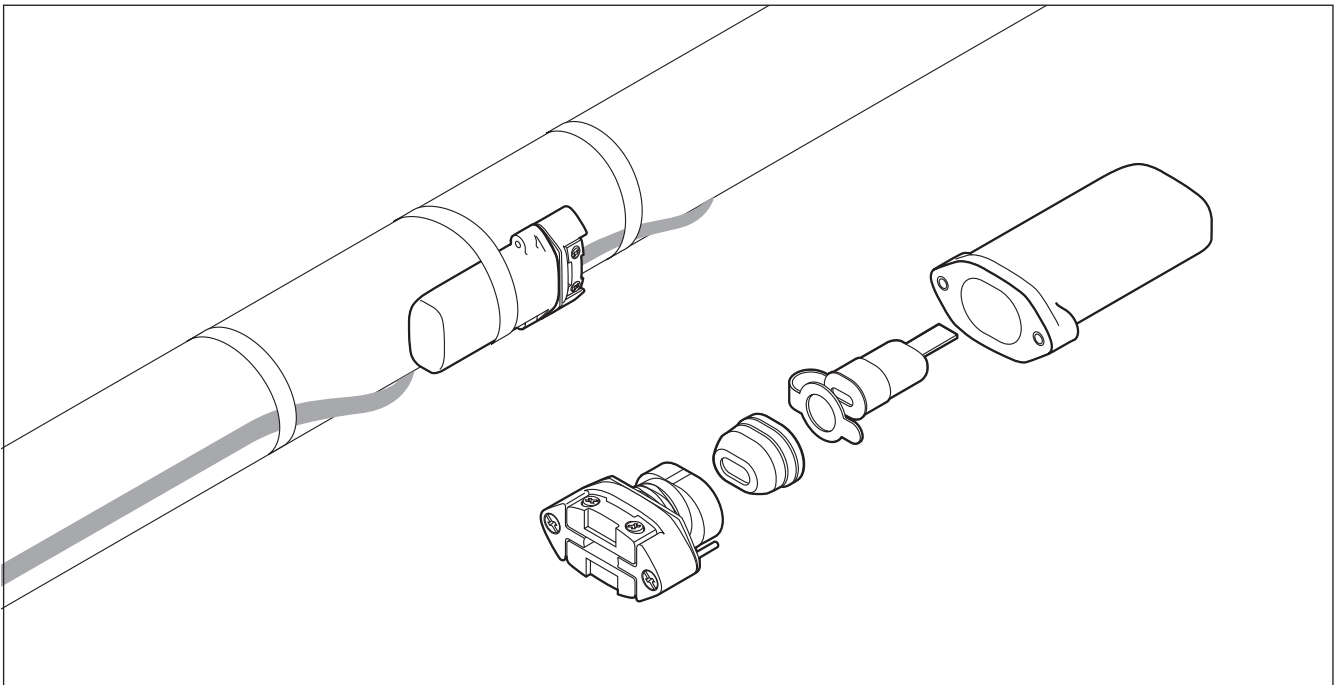
suitable for high temperature variations and aggressive chemical exposure. The end seal is re-enterable. The E-150 design provides a safe under the insulation end seal that can be relied upon over time.

The end seal requires no heat source for installation, making maintenance fast and easy. Each kit contains all the necessary materials to do one end termination.



Description	Cold applied end seal for use with BTV, QTVR, XTV and KTV heating cables.
Kit contents	<ul style="list-style-type: none"> 1 end seal enclosure housing 1 sealing grommet assy 1 core sealing boot 1 identification label 1 installation instruction
Approvals	<div style="display: flex; align-items: flex-start;"> <div style="margin-right: 10px;">  </div> <div> <p>II 2 G/D EEx e II IP 66 PTB 98 ATEX 1121 U</p> <p>DNV Certificate No. E-5121 and E-5122</p> </div> </div> <div style="margin-top: 10px;"> <div style="display: flex; align-items: center;"> <div style="margin-right: 10px;">  </div> <div> <p>Class I, Div. 2, Groups A, B, C, D Class II, Div. 2, Groups F, G Class III</p> </div> </div> <div style="margin-top: 10px;"> <div style="display: flex; align-items: center;"> <div style="margin-right: 10px;">  </div> <div> <p>CLI, ZN2, AEx e II T⁽¹⁾</p> </div> </div> <div style="margin-top: 10px;"> <div style="display: flex; align-items: center;"> <div style="margin-right: 10px;">  </div> <div> <p>Ex e II T⁽¹⁾</p> </div> </div> </div> </div></div>
<p>⁽¹⁾ For T-rating, see heating cable or design documentation</p>	

Dimensions (in mm)

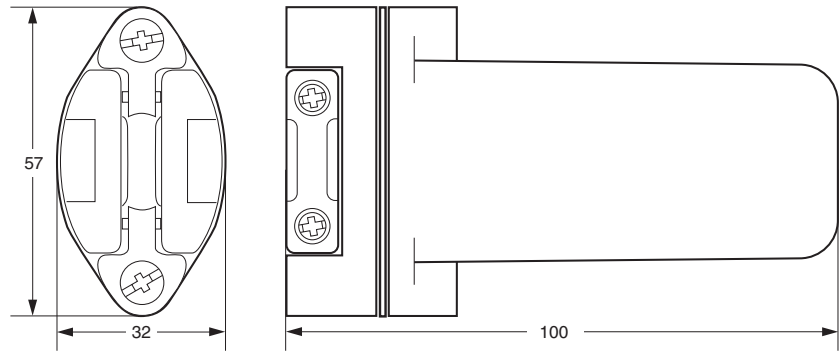

Raychem product specifications

Heating cable capability	BTV-CR, BTV-CT, QTVR-CT, XTV-CT, KTV-CT
Ingress protection	IP66
Minimum installation temperature	-50°C
Maximum pipe temperature	215°C
Operating voltage	277 V for FM and CSA, 254 V for PTB

Materials of construction

Enclosure, end plate, and shim	Engineering polymers, black
Sealing grommet and core sealer	Silicone rubber
Screws, compression spring, reinforcement plate	Stainless steel

Ordering details

End seal	E-150
PN (Weight)	979099-000 (0.3 kg/0.6 lb.)