

End seal kits - heat-shrink

These end seal kits are designed for the termination of Raychem's industrial heating cables.

The E-06 is designed for use with BTV- and QTVR heating cables, where as the E-19 is designed for use with XTV- and KTV heating cables.



All kits are approved for use in hazardous areas.

The end seal kits employs easy to use heat-shrinkable tubing with an adhesive, that when heated forms a semi-flexible moisture proof encapsulation.

Due to its low profile design the finished termination can be installed directly on the pipe.

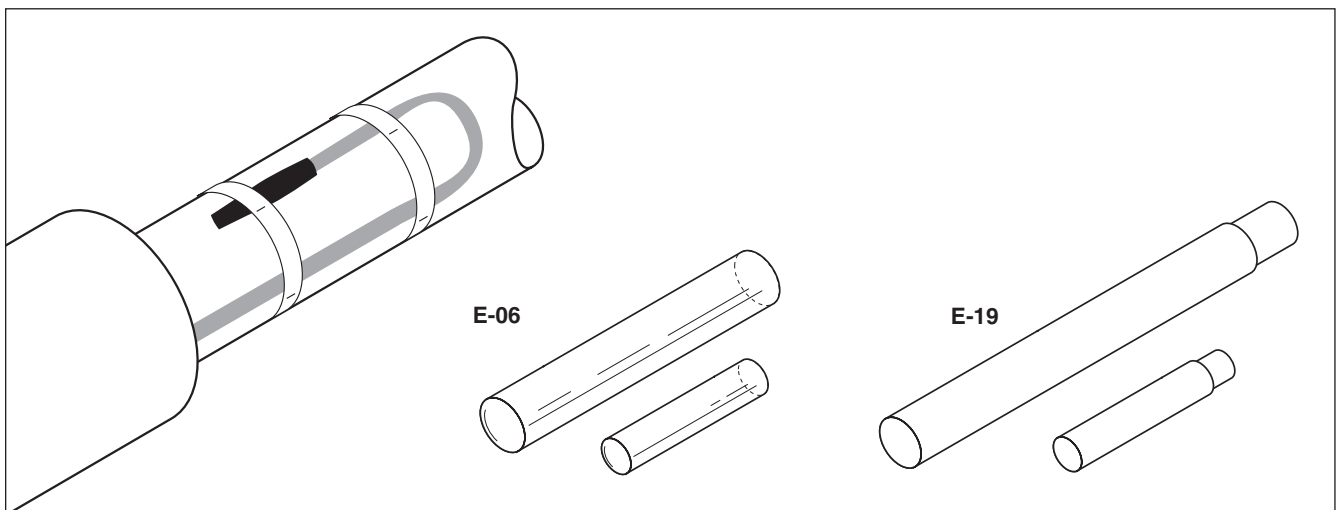
One end seal kit is required for each termination.



	E-06	E-19
Application	End seal for BTV and QTVR self-regulating heating cables	End seal for XTV and KTV self-regulating heating cables
Kit contents	Heat-shrinkable Adhesive coated sleeves Installation instruction	Heat-shrinkable sleeves Adhesive liners Installation instruction
Approvals	 II 2 G/D EEx e II by PTB and Baseefa 2001 Ltd. according to EN 50 014, EN 50 019 DNV Certificate No.E-5121	 II 2 G/D EEx e II by PTB and Baseefa 2001 Ltd. according to EN 50 014, EN 50 019 DNV Certificate No.E-5122
Raychem product specifications		
Max. exposure temperature	175°C	200°C
Dielectric strength	2.2 MV/m	> 6 MV/m
Volume resistivity	10 ¹³ Ω cm	10 ¹⁰ Ω cm
Final dimensions	length approx. 120 mm	length approx. 135 mm
Installation details		
Heat shrinkable tubing	175°C	200°C
Gas torch or equivalent	min. 1460 W hot air gun	min. 1460 W hot air gun
Ordering information		
Part description	E-06	E-19
PN (Weight)	582616-000 (30 g)	090349-000 (50 g)