

REACH ELECTRICAL (S) PTE LTD

51 Ubi Ave 1, #03-05, Paya Ubi Industrial Park, Singapore 408933

Tel: (65) 6296 6860 Fax: (65) 6298 1443

Email: reach@singnet.com.sg

Website: <http://www.reachelectrical.com>

Company's Reg. No. : 199004352W G.S.T Reg. No. M2-0095215-4



Cert. No.: SG02/00221

Paddle Type Flow Switch

Flow Switch utilizes the force of liquid flow to propel it's paddle in order to detect the coming flow or moving liquid or no liquid, the spring is in expanding and press the magnet downward vertically. Reed switch contact is N.O.

As flow occurs and the paddle is thrust and raised at an upward angle of 20 ~ 30 (or more), the eccentric of the paddle will push the magnet upward to actuate the reed switch which is thus in a close circuit. The length of paddle can be adjusted with the diameter of the pipe.

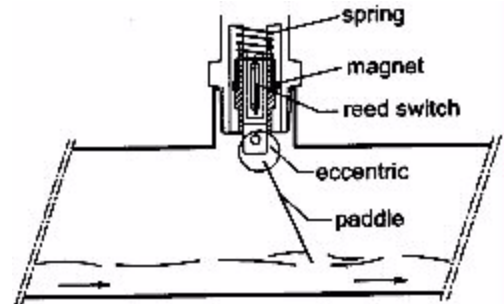

Model : SF1710

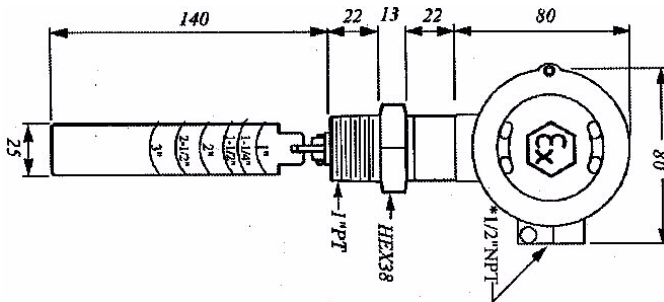

Model : SF1800

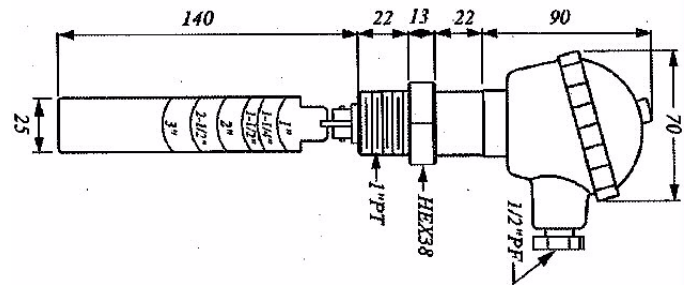

Specification	Model : SF1710	Model : SF1800
Housing Material	Aluminum Alloy, Ex d IIC T6	Aluminum Alloy, IP65
Operation Temperature	-30°C ~ 100°C	-30°C ~ 150°C
Paddle Material	SUS304	SUS304
Operation Pressure	Max. 355 PSIG	Max. 355 PSIG
Pressure Drop Allowance	3 PSIG	3 PSIG
Set Point Tolerance	25 % [^]	25 %
Repeatability Tolerance	5 %	5 %
Contact Capacity	60W, 220V/200 VAC, SPDT	60W, 220V/200 VAC, SPDT

INSTALLATION

1. Paddle length established approx. actuation setting of a Flow Switch unit. Paddle length is decided according to the lowest point of paddle while actuating the reed switch and diameter of the pipe. Cut off the paddle at proper pipes size mark or wherever desired but not less that 1" left.
2. The paddle must be parallel to the cutting face of a pipe and the mounting screw is 1" NPT.
3. The FLOW mark on the screw hexagon must be parallel to the pipe and the ground.
4. Before installing the unit of the pipe, be sure to apply tape seal to the screw the tighten up.

CAUTION

1. The pressure and temperature ranges as shown in the catalogue, must not be exceeded and also take the abrupt pressure and temperature into considerations.
2. Operating temperature changes do affect switch set points. In case of the liquid temperature would vary with the specific gravity changes during processing.
3. The flow switch is designed for shock and vibration should be as minimized as possible.
4. Excessive contamination in fluid might inhibit paddle operation, occasional wipe-down would be necessary
5. Electrical entry and mounting require sealing from moisture